Safe measurement, indication and control of rotational speed



.....**FQ** next generation

Multi-function sensor series





FQ next generation

Multi-function sensor series

Back biased sensor versions

Crankshaft camshaft sensor	details see page 4
Rotational speed sensor, 1 channel / 2 channel	details see page 5
Rotational speed sensor PWM signal, 2 wire / double frequency	
Rotational speed sensor 2 wire / 2 channel current output	details see page 6
Speed sensor with redundant design, 4 channel	details see page 7
Optional: Open-/short diagnose	
Optional: Extended diagnostic for functional safety application	
Optional: Temperature detection	

Ring-magnet sensor versions

Speed sensors, 2 channel for usage with multipole ring-magnets	details see page 8
--	--------------------

Position sensor versions

Angular position	details see page 9
Linear position	

PRELIMINARY



FQ next generation

Basic mechanical features

Basic mechanical features

Cable outlet	180° / 105°
Insertion depth	30 mm / 35 mm / 45 mm - others on request
Module	1.25 resp. on request
Cable lengths	500 mm
Connection	Superseal, Deutsch DT04, JuniorTimer - others on request
Temperature	-40 °C ... +140 °C / +150 °C
Protection	IP67, IP69K (sensor, cable outlet)



FQ next generation Crankshaft sensor

Parameters	Prototype sensor
Supply voltage	4.5 V ... 24 V
Current consumption	≤ 30 mA (depending on load)
Operating frequency	0 Hz ... 20 kHz
Current load	≤ 20 mA
Output	Open collector frequency signal with integrated pull-up resistor
Target module	approx. 2.5
Output polarity @ CCW rotation direction	Low over valley
Phase shift	NA
Duty cycle	50 % ±10 %



Typical target with signature area (36-2 teeth)

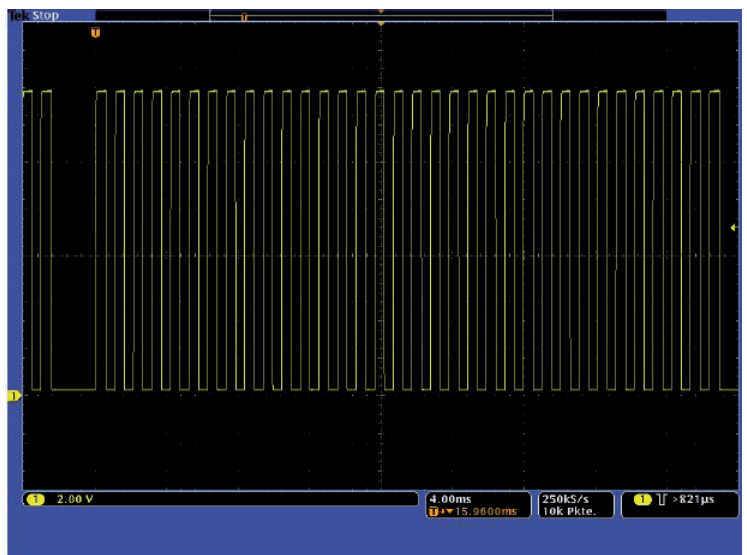

Waveform with 36-2 target



FQ next generation 2-Channel sensor

Parameters	Prototype sensor
Power supply	7 VDC ... 36 VDC
Frequency range	0 Hz ... 40 kHz
Output	NPN
Operation temperature, max.	-40 °C ... +140 °C / -40 °F ... +284 °F
Degree of protection	IP67 / IP69K
Plug	Open leads, Contact pins, Plugs: AMP SUPER-SEAL, AMP Junior Timer, DEUTSCH DT (others on request)
Insertion depth	35 mm, 45 mm (others on request)
Cable length	500 mm, 1200 mm (others on request)
Cable outlet	90° or 180° angle to sensor housing

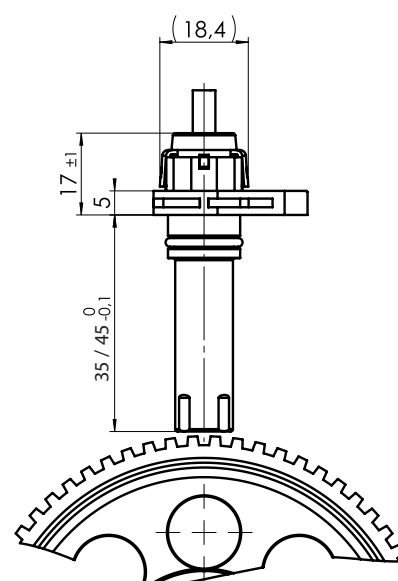



FQ next generation

Speed sensor

2 wire / channel current output

Parameters	Prototype sensor
Supply voltage	4 V ... 24 V
Reverse voltage protection	-18 V
Supply current	ICC (High) 12 mA ... 16 mA ICC (Low) 4 mA ... 8 mA
Operating frequency	0 Hz ... 12 kHz
Output ch A / ch B	Current source frequency signals
Output rise time	5 μ s (max) from 10 % to 90 % ICC level, $R_{SENSE} = 100 \Omega$
Output fall time	5 μ s (max) from 90 % to 10 % ICC level, $R_{SENSE} = 100 \Omega$
Cable outlet	180° angle to the sensor housing
Target module	2.0 - other modules possible
Airgap	0.25 mm ... 2.5 mm @ module 2.0
Phase shift	90° \pm 45°
Duty cycle	50 % \pm 10 %
Optional: Safe state output protocol	Integrated sensor diagnosis continuously monitors failures/defects within the device and reports to the ECU with a safe state output protocol

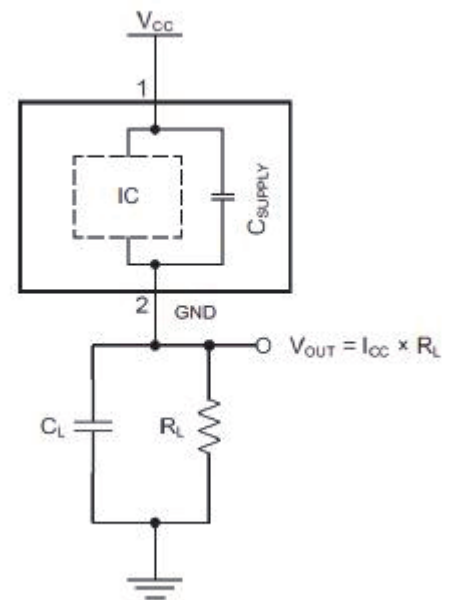
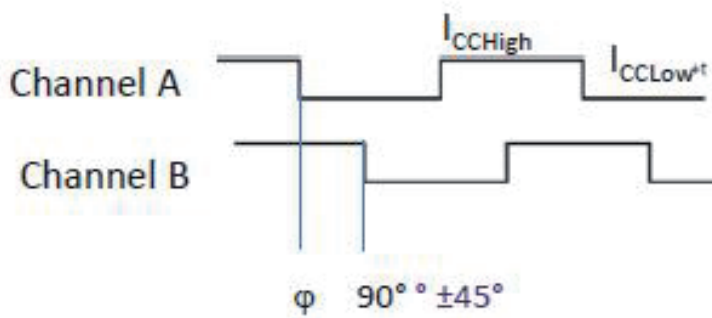

Figure: Typical application circuit





FQ next generation

Speed sensor with redundant design, 4 channel

Traditional solution using 2 independent 2 channel sensors

New 4 channel solution using one sensor with integrated 2 x 2 channel sensor (2 x AB signals)

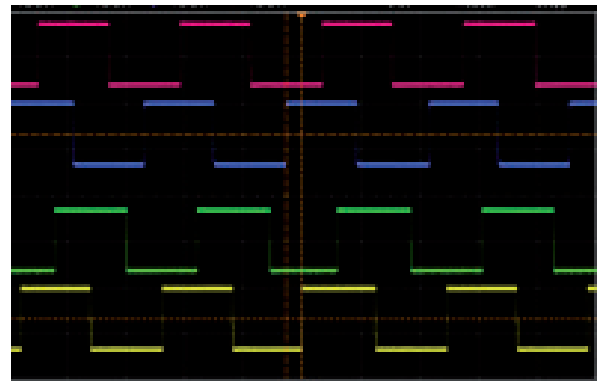
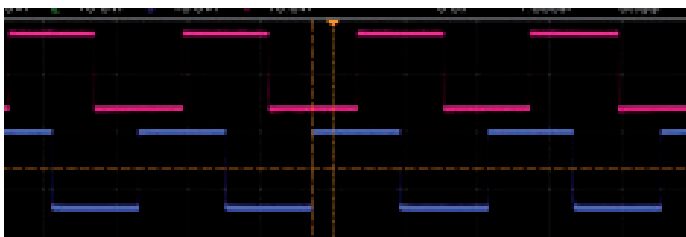
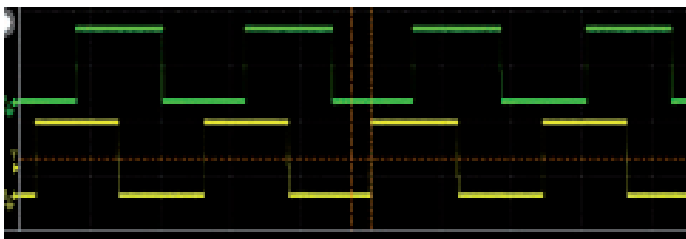



FQ next generation Ring-magnet version

Features

- ◆ Speed sensor works with various multipole magnets
- ◆ 2 channel open drain quadrature output
 - » 90° phase shift with various magnet sizes
- ◆ Available in various housing options up to IP67/IP69k
- ◆ Large airgap range capability
- ◆ Position tolerant system
- ◆ Optional:
 - » Fully redundant 4 channel sensor system
 - » Open/Short diagnostic
- ◆ Extended temperature range: -40 °C ... +150 °C

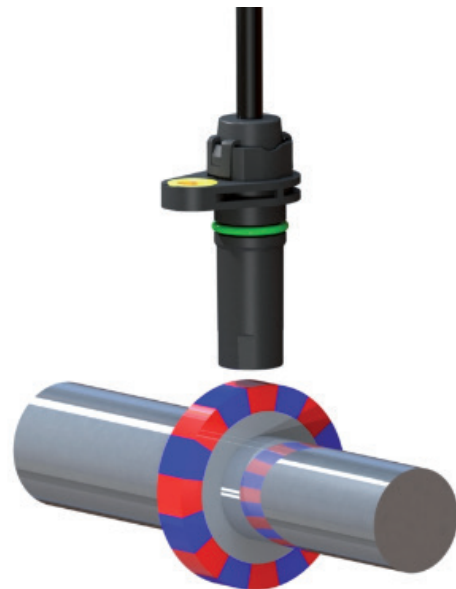

Output Response to a
Speed and Direction Part

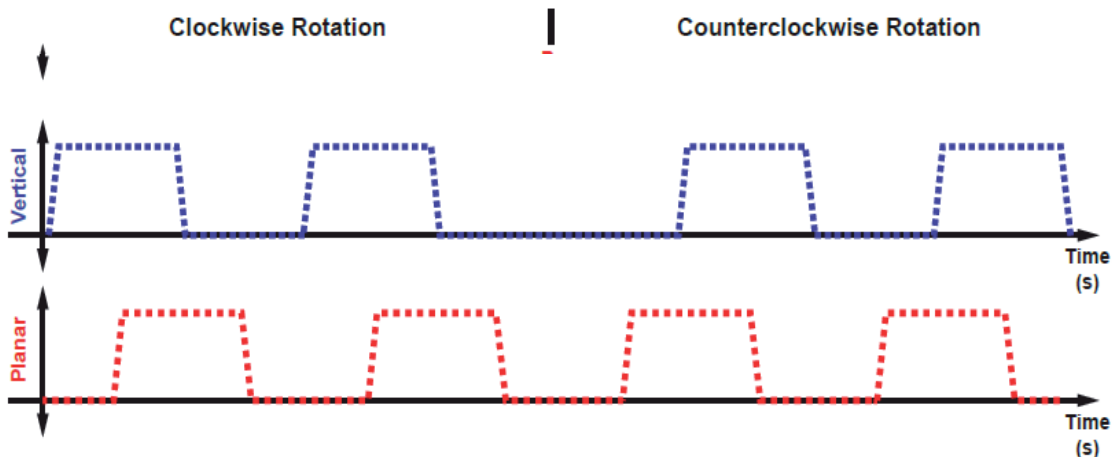



FQ next generation

Angular position sensor

Features

- ◆ Angle sensor with radial detection capability of ring magnets
- ◆ Absolute angle position with ratiometric analog voltage output (0.5 V ... 4.5 V) or with PWM output
- ◆ Available in various housing options up to IP67/IP69k
- ◆ Large airgap range capability
- ◆ Position tolerant system:
 - » Axial position tolerance ± 1.0 mm
 - » Airgap variation up to 2 mm
- ◆ Optional:
 - » Fully redundant 2 channel sensor system
 - » Phase shifted signals for additional plausibility
- ◆ Typical angle error $< \pm 2.0^\circ$
- ◆ Extended temperature range: -40 °C ... $+150$ °C

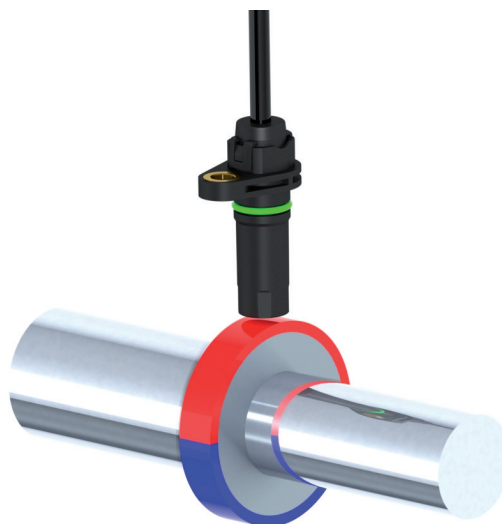

Output signals two channel version

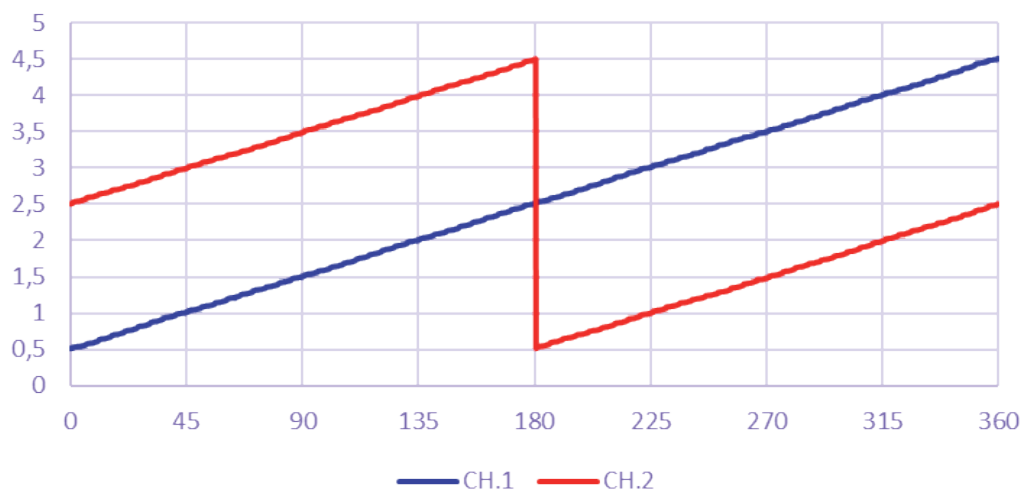



About us

RHEINTACHO Messtechnik GmbH has been engaged since 1901 in the field of rotational speed, a crucial control quantity for mechanical processes.

The production range incorporates sensors, hand-held measuring devices, rotary encoders and switching devices.

Just over 100 employees are employed at the company's headquarters in Freiburg. In-house product development, production and assembly departments guarantee quick and innovative solutions to customers' individual requirements.

Our products are available worldwide through our subsidiaries and sales partners. With a committed and competent customer service, we ensure first-class application advice around the globe.

RHEINTACHO Messtechnik GmbH

Waltershofener Str. 1
79111 Freiburg · Germany
Tel: +49 (0)761 4513 0
info@rheintacho.de

